

DILATATIONALLY NONLINEAR ELASTIC MATERIALS—II. AN EXAMPLE ILLUSTRATING STRESS CONCENTRATION REDUCTION†

ROHAN ABEYARATNE and GUO-HUA JIANG

Department of Mechanical Engineering, Massachusetts Institute of Technology, Cambridge, MA 02139, U.S.A.

(Received 28 October 1988; in revised form 3 March 1989)

Abstract—This paper, which is the second in a two-part study, uses a specific boundary-value problem to illustrate some of the features of the theory discussed in the first part. Here, the spherically symmetric deformation of a hollow sphere which has a traction-free inner wall and a prescribed radial displacement δ at its outer wall is studied. The analysis is carried out within the small-strain theory of nonlinear elasticity and the body is assumed to be composed of an elastic material which is homogeneous and isotropic, and which has a linear response in shear and a tri-linear response in dilatation.

For a certain range of values of the applied displacement δ , the problem has an *infinity* of solutions and these describe configurations which involve a phase boundary; the strain field is continuous on either side of the phase boundary but suffers a jump discontinuity across it. A "kinetic law", which is a supplementary constitutive law pertaining to particles located on the phase boundary and relating the driving traction on the phase boundary to its velocity, is then imposed, leading to a unique response in all quasi-static motions.

As δ increases monotonically during a quasi-static motion, the hoop stress at the cavity first increases, then decreases discontinuously as the phase boundary emerges from the cavity wall, next increases slowly (or, for certain special kinetic laws, remains constant) as the phase boundary propagates outwards, and finally commences to increase at the original rate once the body has been fully transformed.

1. INTRODUCTION

The fracture toughness of certain ceramic composites containing second phase particles which undergo a stress-induced phase transformation is known to be higher than that of the brittle ceramic matrix (Garvie *et al.*, 1975; Evans and Cannon, 1986). A number of recent studies, beginning with the work of McMeeking and Evans (1982) and Budiansky *et al.* (1983), have been aimed at providing a continuum mechanical model which can predict the observed *stress intensity factor* reduction at a crack-tip in such materials; see also Lambropoulos (1986), Amazigo and Budiansky (1987, 1988), Ortiz (1987) and Silling (1987).

In this paper we examine a much simpler, but related, problem. We consider the spherically symmetric deformation of a hollow sphere which has a traction-free inner wall and a prescribed radial displacement δ at its outer wall. Here, one expects to observe a reduction in the *stress concentration factor* at the cavity in the case when the sphere is composed of a transforming ceramic material as when compared to the case when it is composed of the ceramic matrix. We obtain a closed form analytical solution to this problem, and use it to illustrate certain features of boundary-value problems for such materials.

The analysis here is carried out within the small-strain theory of nonlinear elasticity, and utilizes the particular constitutive law proposed by Budiansky *et al.* (1983) for the special case of "supercritical transformations"; this constitutive law describes a class of elastic materials which is homogeneous and isotropic, and which has a linear response in shear and a tri-linear dilatational response. Certain theoretical issues pertaining to such materials were examined in Part I of this study (Abeyaratne and Jiang, 1989).

We show that, for all sufficiently small values of the prescribed displacement δ , the boundary-value problem has a unique solution and that it corresponds to a configuration

† The results reported here were obtained in the course of an investigation supported in part by the U.S. Office of Naval Research.

of the body in which the strain field varies continuously (a "fully untransformed configuration"); this is also true for all large enough values of δ (in which case the body is in a "fully transformed configuration"). On the other hand, for a certain intermediate range of values of δ the problem has an *infinity* of solutions and these describe configurations which involve a phase boundary ("partially transformed configurations"). The strain field is continuous on either side of the phase boundary but suffers a jump discontinuity across it; the displacement field is continuous everywhere.

In view of this massive failure of uniqueness, we are led to conclude that the theory, as formulated, is deficient. Presumably, this deficiency is constitutive, and moreover, is intimately related to the presence of a phase boundary. Accordingly, in Section 5 we supplement the theory with an additional constitutive law (a "kinetic law") which pertains (only) to particles located on the phase boundary. Since quasi-static motions which involve moving phase boundaries are generally dissipative (even in nominally elastic materials, see Knowles, 1979), it is possible to define a notion of a driving traction on a phase boundary; the kinetic law relates the driving traction to the velocity of the moving phase boundary.

While the kinetic law governs the evolution of a phase boundary once it has been initiated, a separate criterion is needed in order to signal the first appearance of the phase boundary. The "initiation criterion" used here is that a phase boundary will emerge when the driving traction on it reaches a certain critical value. In the present theory, this is equivalent to an initiation criterion based on a critical value of the dilatation.

It is found that, as the given displacement δ increases monotonically during a quasi-static motion, the hoop stress at the cavity first increases, then decreases discontinuously as the phase boundary emerges from the cavity wall, next increases slowly (or, for certain special kinetic laws, remains constant) as the phase boundary propagates outwards, and finally commences to increase at the original rate once the body has been fully transformed. In general, the response is rate-dependent and dissipative, though for two special kinetic laws it is rate-independent; in one of these special cases the response is dissipation-free, while in the other it is "plasticity-like".

2. CAVITY PROBLEM

Consider a hollow sphere of internal radius a and external radius b . Suppose that the outer surface of the sphere is subjected to a radial displacement δ while its inner surface remains free of traction. The resulting deformation of the sphere is assumed to be purely radial with $u(r)$ denoting the radial component of displacement; u is required to be continuous on $a \leq r \leq b$, and for some $s \in (a, b)$ it is to be twice continuously differentiable on $(a, s) + (s, b)$. If u' is discontinuous at $r = s$, we refer to the circle $r = s$ as an *equilibrium shock* or *phase boundary*. The spherical components of strain associated with this deformation are

$$\left. \begin{aligned} \varepsilon_{rr} &= u'(r), & \varepsilon_{\theta\theta} &= \varepsilon_{\phi\phi} = u(r)/r \\ \varepsilon_{r\theta} &= \varepsilon_{\theta\phi} = \varepsilon_{r\phi} = 0 \end{aligned} \right\} \text{ for } r \neq s \quad (1)$$

and the corresponding dilatation $\Delta(r)$ is

$$\Delta(r) = u'(r) + 2u(r)/r \quad \text{for } r \neq s. \quad (2)$$

Suppose that the sphere is composed of an isotropic elastic material whose stress-strain relation is

$$\sigma = 2\mu\varepsilon + (\hat{\sigma}(\Delta) - 2\mu\Delta/3)\mathbf{1}; \quad (3)$$

$\mu (> 0)$ is the shear modulus of the material and $\hat{\sigma}(\Delta)$ is a constitutive function. Various properties of this class of materials were examined in Part I. Here we simply note that the

stress response of this material in simple shear is linear, while $\hat{\sigma}(\Delta)$ denotes its *stress response function in pure dilatation*. From (1)–(3), the components of stress in the sphere are

$$\left. \begin{aligned} \sigma_{rr} &= \hat{\sigma}(\Delta(r)) + (4\mu/3)\{u'(r) - u(r)/r\} \\ \sigma_{\theta\theta} &= \sigma_{\phi\phi} = \hat{\sigma}(\Delta(r)) - (2\mu/3)\{u'(r) - u(r)/r\} \\ \sigma_{r\theta} &= \sigma_{\theta\phi} = \sigma_{r\phi} = 0 \end{aligned} \right\} \text{ for } r \neq s. \tag{4}$$

Equilibrium requires

$$\left. \begin{aligned} d\sigma_{rr}/dr + 2(\sigma_{rr} - \sigma_{\theta\theta})/r &= 0 \\ \sigma_{rr}(s-) &= \sigma_{rr}(s+). \end{aligned} \right\} \text{ for } r \neq s \tag{5}$$

$$\tag{6}$$

Equation (5), in view of (4), (2), leads to

$$\frac{d}{dr} \Sigma(\Delta(r)) = 0 \quad \text{for } r \neq s \tag{7}$$

where Σ is defined by

$$\Sigma(\Delta) = \hat{\sigma}(\Delta) + 4\mu\Delta/3 \quad \text{for } -\infty < \Delta < \infty. \tag{8}$$

(It can be readily shown from (8), (3) that Σ may be interpreted as the stress response function of the material in uni-axial deformation.) Integrating (7) leads to $\Sigma(\Delta(r)) = c_1$ for $a < r < s$ and $\Sigma(\Delta(r)) = c_2$ for $s < r < b$ where c_1 and c_2 are constants. However, as shown in Part I of this study (see (33) of Abeyaratne and Jiang, 1989), displacement and traction continuity across $r = s$ requires $\Sigma(\Delta(r))$ to be continuous and so, (7) in fact leads to

$$\Sigma(\Delta(r)) = c \quad \text{for } r \neq s. \tag{9}$$

The *cavity problem* consists of finding a displacement field $u(r)$ which obeys equations (2), (9), the boundary conditions

$$u(b) = \delta \tag{10}$$

$$\sigma_{rr}(a) = \hat{\sigma}(\Delta(a)) + (4\mu/3)\{u'(a) - u(a)/a\} = 0 \tag{11}$$

and the displacement continuity requirement $u(s-) = u(s+)$.

3. DISPLACEMENT FIELDS

In this section we will solve the cavity problem for the particular class of materials characterized by the dilatational response function

$$\hat{\sigma}(\Delta) = \begin{cases} \beta\Delta & \text{for } -\Delta_m \leq \Delta \leq \Delta_m \\ \beta\Delta + \sigma_T(\Delta - \Delta_m)/(\Delta_m - \Delta_m) & \text{for } \Delta_m \leq \Delta \leq \Delta_m \\ \beta\Delta + \sigma_T & \text{for } \Delta \geq \Delta_m; \end{cases} \tag{12}$$

β , Δ_m , Δ_M and σ_T are material constants such that

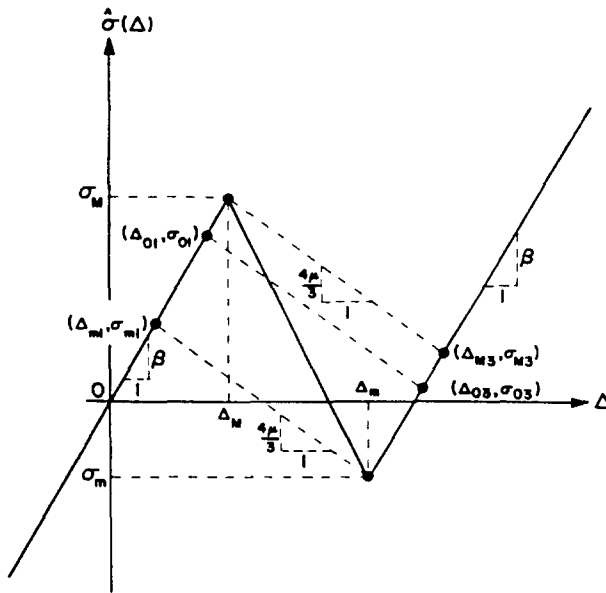

Fig. 1. Stress response curve in pure dilatation.

$$\left. \begin{aligned} \beta > 0, \quad \Delta_m > \Delta_M > 0, \quad \sigma_T < 0 \\ -\beta\Delta_M \leq \beta\Delta_m + \sigma_T < 0 \\ (\Delta_m - \Delta_M)(\beta + 4\mu/3) < -\sigma_T. \end{aligned} \right\} \quad (13)$$

A graph of the function $\hat{\sigma}(\Delta)$ is shown in Fig. 1. Requirement (13)₂ implies that $\hat{\sigma}(-\Delta_M) \leq \hat{\sigma}(\Delta_m) < 0$. The significance of (13)₃ will be discussed shortly. The tri-linear dilatational response function (12) was used by Budiansky *et al.* (1983) for characterizing the response of certain transforming ceramics. The only difference between (12), (13) and the choice made by Budiansky *et al.* (1983) is that we take $\hat{\sigma}(\Delta_m)$ to be negative; this feature is needed in our analysis in order to allow for the occurrence of permanent deformations. From (8), the uniaxial deformation response function Σ associated with (12) is

$$\Sigma(\Delta) = \begin{cases} \alpha\Delta & \text{for } -\Delta_M \leq \Delta \leq \Delta_M \\ \alpha\Delta + \sigma_T(\Delta - \Delta_M)/(\Delta_m - \Delta_M) & \text{for } \Delta_M \leq \Delta \leq \Delta_m \\ \alpha\Delta + \sigma_T & \text{for } \Delta \geq \Delta_m \end{cases} \quad (14a)$$

where

$$\alpha = \beta + 4\mu/3. \quad (14b)$$

The third condition in (13) ensures that $\Sigma(\Delta_M) > \Sigma(\Delta_m)$ so that $\Sigma'(\Delta)$ is negative on (Δ_M, Δ_m) . As shown in Part I (see discussion following (33) in Part I), this condition is necessary and sufficient for the material to be able to sustain equilibrium deformations with discontinuous strains. [In the terminology of Budiansky *et al.* (1983) when this condition holds, the material can undergo a “supercritical phase transformation”.] The graph of $\Sigma(\Delta)$ is shown in Fig. 2; the number $\Sigma_o \equiv (\Sigma_M + \Sigma_m)/2$. The figure has been drawn in the case $\Sigma_m > 0$, though this is not assumed in the analysis.

Finally, we introduce some additional notation which will simplify some of the formulae that we will encounter in Sections 4 and 5. This notation pertains to certain special points on the stress-strain curves shown in Figs 1 and 2. We emphasize that the constitutive law (3), (12), involves only the five material constants μ , β , Δ_m , Δ_M and σ_T ; the quantities which follow can all be expressed solely in terms of these basic quantities:

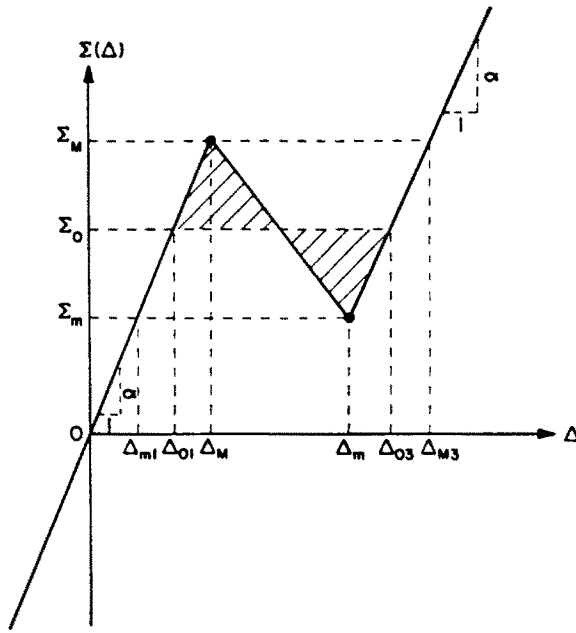

Fig. 2. Stress response curve in uni-axial deformation.

$$\left. \begin{aligned}
 \sigma_m &= \beta\Delta_m + \sigma_T, & \sigma_{m1} &= \sigma_m - \sigma_T(1 - \beta/\alpha) \\
 \sigma_M &= \beta\Delta_M, & \sigma_{M3} &= \sigma_M + \sigma_T(1 - \beta/\alpha) \\
 \sigma_{o1} &= (\sigma_M + \sigma_m)/2 - \sigma_T(1 - \beta/\alpha)/2, & \sigma_{o3} &= \sigma_{o1} + \sigma_T(1 - \beta/\alpha) \\
 \Sigma_m &= \alpha\Delta_m + \sigma_T, & \Sigma_M &= \alpha\Delta_M \\
 \Delta_{m1} &= \Delta_m + \sigma_T/\alpha, & \Delta_{M3} &= \Delta_M - \sigma_T/\alpha \\
 \Delta_{o1} &= (\Delta_m + \Delta_M)/2 + \sigma_T/2\alpha, & \Delta_{o3} &= (\Delta_m + \Delta_M)/2 - \sigma_T/2\alpha.
 \end{aligned} \right\} \quad (15)$$

Observe that the points $(\Delta_{m1}, \sigma_{m1})$, $(\Delta_{o1}, \sigma_{o1})$ and (Δ_M, σ_M) lie on the first branch of the stress-strain curve $\sigma = \hat{\sigma}(\Delta)$ (hence the subscript 1), while the points (Δ_m, σ_m) , $(\Delta_{o3}, \sigma_{o3})$ and $(\Delta_{M3}, \sigma_{M3})$ lie on the third branch (hence the subscript 3). Moreover (Δ_M, σ_M) is a local maximum of this curve (hence the subscript M) while (Δ_m, σ_m) is a local minimum (hence the subscript m). Note also that the three straight lines which join (Δ_M, σ_M) to $(\Delta_{M3}, \sigma_{M3})$, $(\Delta_{o1}, \sigma_{o1})$ to $(\Delta_{o3}, \sigma_{o3})$, and $(\Delta_{m1}, \sigma_{m1})$ to (Δ_m, σ_m) each have the same slope $-4\mu/3$. The points $(\Delta_{o1}, \sigma_{o1})$ and $(\Delta_{o3}, \sigma_{o3})$ correspond to so-called Maxwell-states; they have the property that $\Sigma(\Delta_{o1}) = \Sigma(\Delta_{o3}) = \Sigma_o \equiv (\Sigma_m + \Sigma_M)/2$.

We now return to the cavity problem and first consider the case in which the displacement field is smooth. Suppose that the dilatation $\Delta(r)$ is such that $-\Delta_M \leq \Delta(r) \leq \Delta_m$ for $a \leq r \leq b$, so that all particles in the body are associated with the *first* branch of the stress-strain curve (i.e. all particles are “untransformed”). By (2), (9), (14) it then follows that

$$u'(r) + 2u(r)/r = c/\alpha \quad \text{for } a \leq r \leq b. \quad (16)$$

Integrating (16) and enforcing the boundary conditions (10), (11) leads to the following expression for the displacement field.

$$u(r) = (\delta b^2/q) \{ \kappa r/a^3 + (1 - \kappa)/r^2 \} \quad \text{for } a \leq r \leq b \quad (17)$$

where we have set

$$\kappa = 4\mu/3\alpha (< 1), \quad q = 1 + ((b^3/a^3) - 1)\kappa (> 1). \tag{18}$$

On using (17) and (2), the requirement $|\Delta(r)| \leq \Delta_M$ yields $|\delta| \leq \delta_M$, where

$$\delta_M \equiv (q\Delta_M a^3)/(3\kappa b^2). \tag{19}$$

Next, suppose that the dilatation is such that $\Delta(r) \geq \Delta_m$ for $a \leq r \leq b$ so that all particles in the body are associated with the *third* branch of the stress-strain curve (i.e. all particles are "transformed"). By (2), (9) and (14) it then follows that

$$u'(r) + 2u(r)/r = (c - \sigma_T)/\alpha \quad \text{for } a \leq r \leq b. \tag{20}$$

The displacement field may now be found by integrating (20) and enforcing the boundary conditions (10), (11). This yields

$$u(r) = (\delta b^2/q) \{ \kappa r/a^3 + (1 - \kappa)/r^2 \} - (\sigma_T/3\alpha q) \{ r - b^3/r^2 \} \quad \text{for } a \leq r \leq b \tag{21}$$

where κ and q were defined in (18). On using (21) and (2), the requirement $\Delta(r) \geq \Delta_m$ yields $\delta \geq \delta_m$ where

$$\delta_m \equiv (q\Delta_m a^3)/(3\kappa b^2) + (\sigma_T a^3)/(4\mu b^2). \tag{22}$$

Finally, we consider deformations that involve a phase boundary at $r = s$. Suppose that $\Delta(r) \geq \Delta_m$ for $a < r < s$ and that $|\Delta(r)| \leq \Delta_M$ for $s < r < b$, so that all particles within the phase boundary are associated with the *third* branch of the stress-strain curve while the particles outside the phase boundary are associated with the *first* branch of the stress-strain curve (i.e. the body is in a "partially transformed configuration" with the particles within the phase boundary transformed and those outside untransformed). From (2), (9) and (14) it follows that

$$u'(r) + 2u(r)/r = \begin{cases} (c - \sigma_T)/\alpha & \text{for } a < r < s \\ c/\alpha & \text{for } s < r < b. \end{cases} \tag{23}$$

Integrating (23) and enforcing the boundary conditions (10), (11) and the displacement continuity condition $u(s-) = u(s+)$ leads to

$$u(r) = \begin{cases} (\delta b^2/q) \{ \kappa r/a^3 + (1 - \kappa)/r^2 \} - (\sigma_T/3\alpha q) \cdot \{ (\kappa b^3/a^3)(1 - s^3/b^3)(1 - a^3/r^3) + (1 - s^3/r^3) \} & \text{for } a \leq r \leq s \\ (\delta b^2/q) \{ \kappa r/a^3 + (1 - \kappa)/r^2 \} - (\kappa\sigma_T/3\alpha q) \cdot (1 - b^3/r^3)(1 - s^3/a^3) & \text{for } s \leq r \leq b. \end{cases} \tag{24}$$

The restrictions on $\Delta(r)$ that were assumed in deriving (24) can now be written by using (24), (2) as

$$\delta_M - \sigma_T(s^3 - a^3)/(3\alpha b^2) \geq \delta \geq \delta_m + \sigma_T(b^3 - s^3)/(3\alpha b^2) \tag{25}$$

where δ_M and δ_m are given by (19), (22).

While there are other cases to be considered (for example $\Delta(r) \geq \Delta_m$ for $s < r < b$ and $|\Delta(r)| \leq \Delta_M$ for $a < r < s$) the three cases considered above are the most important ones. Arguments similar to those used by Abeyaratne and Knowles (1987) can be used to show that the remaining cases cannot occur in any quasi-static motion which commences from a fully untransformed state, provided the motion conforms with the second law of thermodynamics under isothermal conditions.

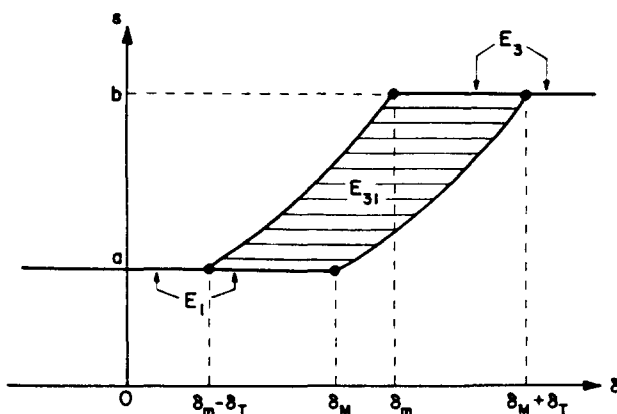

Fig. 3. Parameter sets E_1, E_3, E_{31} in (δ, s) -plane.

In order to summarize the preceding results we consider the following sets E_1, E_3 and E_{31} of the (δ, s) -plane:

$$E_1 = \{(\delta, s) \mid |\delta| \leq \delta_M, \quad s = a\} \tag{26}$$

$$E_3 = \{(\delta, s) \mid \delta \geq \delta_m, \quad s = b\} \tag{27}$$

$$E_{31} = \{(\delta, s) \mid \delta_M - \sigma_T(s^3 - a^3)/(3\alpha b^2) \geq \delta \geq \delta_m + \sigma_T(b^3 - s^3)/(3\alpha b^2), \quad a < s < b\}. \tag{28}$$

These domains are sketched in Fig. 3 where δ_T is defined by

$$\delta_T = -\sigma_T(b^3 - a^3)/(3\alpha b^2). \tag{29}$$

While the figure has been drawn for the case $\delta_m > \delta_M$, our analysis is not restricted to this case. It follows from the analysis surrounding (16)–(19) that if (δ, s) is a point in E_1 , then $u(r)$ as given by (17) is a solution to the cavity problem. Similarly if (δ, s) is respectively in E_3 or E_{31} , a solution to the cavity problem is given by (21) or (24). It is now clear that the cavity problem, as formulated, suffers from a massive failure of uniqueness. Observe from Fig. 3, that if the prescribed value of the displacement δ is sufficiently small ($-\delta_M \leq \delta \leq \delta_m - \delta_T$), the problem has a unique solution (and that it coincides with a “fully untransformed” configuration). Similarly if δ is sufficiently large ($\delta \geq \delta_m + \delta_T$), the problem again has a unique solution (this time corresponding to a “fully transformed” configuration). On the other hand when the given value of δ lies in the intermediate range $\delta_m - \delta_T < \delta < \delta_m + \delta_T$, the problem has an infinite number of solutions (since the value of s is essentially arbitrary).

4. HOOP STRESS AT THE CAVITY

Our primary interest in this paper is to examine the relation between the *hoop stress at the cavity wall* $\sigma_c \equiv \sigma_{\theta\theta}(a)$ and the applied displacement δ . In the case of an untransformed configuration, one finds from (4)₂, (12) and (17) that σ_c is given by

$$\sigma_c = (3\sigma_M/2\delta_M)\delta. \tag{30}$$

Similarly for a fully transformed configuration, (4)₂, (12) and (21) give

$$\sigma_c = (3\sigma_M/2\delta_M)\delta + 3\kappa\sigma_T b^3/2qa^3 \tag{31}$$

while for a partially transformed configuration

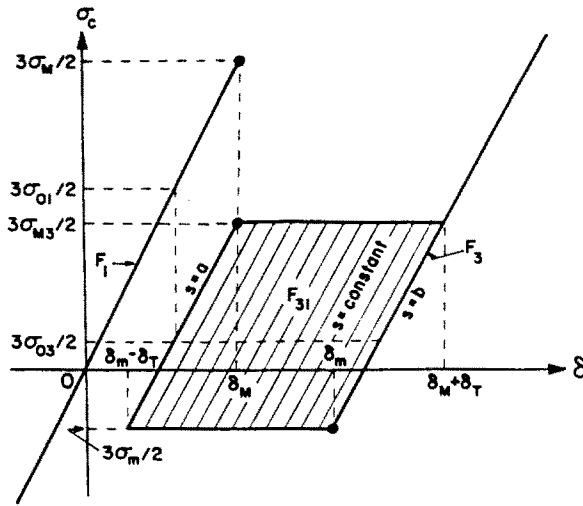

Fig. 4. Regions F_1, F_3, F_{31} of the (δ, σ_c) -plane.

$$\sigma_c = (3\sigma_M/2\delta_M)\delta + (3\kappa\sigma_T/2qa^3)(\kappa b^3 + (1-\kappa)s^3) \tag{32}$$

by (4)₂, (12) and (24).

The regions E_1, E_3 and E_{31} in the (δ, s) -plane are carried by the respective mappings (30), (31) and (32) onto the following domains F_1, F_3 and F_{31} of the (δ, σ_c) -plane:

$$F_1 = \{(\delta, \sigma_c) \mid \sigma_c = 6\mu(1-\kappa)b^2\delta/a^3q, \quad |\delta| \leq \delta_m\} \tag{33}$$

$$F_3 = \{(\delta, \sigma_c) \mid \sigma_c = 6\mu(1-\kappa)b^2\delta/a^3q + (3\kappa\sigma_T b^3/2qa^3), \quad \delta \geq \delta_m\} \tag{34}$$

$$F_{31} = \{(\delta, \sigma_c) \mid \sigma_c - 3\kappa\sigma_T/2 < 3\sigma_M\delta/2\delta_M < \sigma_c - 3\kappa\sigma_T b^3/2qa^3, \quad 3\sigma_m/2 \leq \sigma_c \leq 3\sigma_{M3}/2\}. \tag{35}$$

Figure 4 displays these regions; F_1 and F_3 are parallel straight lines, while F_{31} is a parallelogram. The lines $s = \text{constant}$ in E_{31} are mapped onto a family of parallel lines in F_{31} . Observe that part of F_3 coincides with one of the boundaries of F_{31} , but that this is not so of F_1 . The quantities $\delta_m, \delta_m, \delta_T$ are given by (19), (22) and (29), while the numbers $\sigma_m, \sigma_{O3}, \sigma_{M3}, \sigma_{O1}$ and σ_M are given by (15). While Fig. 4 has been drawn for the case $\sigma_{O3} > 0$, this is not assumed in the analysis.

5. KINETICS

In order to complete the analysis, we must account for the kinetics of the transformation. Let $\overset{+}{\Delta}, \overset{-}{\Delta}, \overset{+}{\Sigma}, \overset{-}{\Sigma}$, denote

$$\overset{+}{\Delta} = \Delta(s+), \quad \overset{-}{\Delta} = \Delta(s-), \quad \overset{+}{\Sigma} = \overset{-}{\Sigma} = \Sigma(\overset{+}{\Delta}) = \Sigma(\overset{-}{\Delta}). \tag{36}$$

Then, the *driving traction* (the driving force per unit area) on the phase boundary is (see equation (48) of Part I)

$$f = \int_{\overset{-}{\Delta}}^{\overset{+}{\Delta}} \Sigma(\Delta) \, d\Delta - \Sigma(\overset{+}{\Delta})(\overset{+}{\Delta} - \overset{-}{\Delta}). \tag{37}$$

On using the constitutive law (14), this simplifies to

$$f = (-\sigma_T/\alpha)\{\bar{\Sigma}^+ - (\Sigma_M + \Sigma_m)/2\} \quad (38)$$

in the case of a partially transformed configuration characterized by (24). Here Σ_M and Σ_m are as defined previously in (15) and have the meanings shown in Fig. 2. Note that f vanishes when $\bar{\Sigma}^+ = \Sigma_o$, where

$$\Sigma_o \equiv (\Sigma_M + \Sigma_m)/2; \quad (39)$$

Σ_o is called the *Maxwell stress* and has the property that the two hatched areas in Fig. 2 are equal. Since $\Sigma_m \leq \bar{\Sigma}^+ \leq \Sigma_M$, the greatest and least values of the driving traction (38) are

$$f_M = -\sigma_T(\Sigma_M - \Sigma_m)/2\alpha (>0) \quad (40)$$

$$f_m = \sigma_T(\Sigma_M - \Sigma_m)/2\alpha (<0) \quad (41)$$

respectively.

Now consider a quasi-static motion of the body on a time interval $[t_0, t_1]$. The lack of uniqueness observed previously suggests that the theory, as formulated, suffers from a constitutive deficiency. A *kinetic law* is a supplementary constitutive relation: it applies to particles located on the phase boundary and relates the driving traction f (and possibly other local quantities as well) to the velocity \dot{s} of the phase boundary. An example of such a kinetic law is

$$\dot{s}(t) = V(f(t)) \quad \text{for } t_0 \leq t \leq t_1 \quad (42)$$

where V is a constitutive function; V is defined and suitably smooth on the interval $[f_m, f_M]$. In order to be consistent with the second law of thermodynamics under isothermal conditions, V must obey (see (52) of Part I)

$$V(f)f \geq 0 \quad \text{for } f_m \leq f \leq f_M. \quad (43)$$

Returning to the cavity problem, suppose that at every instant t during the time interval $[t_0, t_1]$ the body takes on a partially transformed configuration; the displacement field in the sphere is then given by (24) with s and δ replaced by $s(t)$ and $\delta(t)$. In this event, we find from (24), (2), (14) and (36) that

$$\bar{\Sigma}^+ = 3\alpha\delta b^2\kappa/qa^3 + (\kappa\sigma_T/q)(s^3/a^3 - 1). \quad (44)$$

Substituting (44) into (38) expresses the driving traction in terms of δ and s . Combining the resulting equation with (42) yields the following first order differential equation for $s(t)$:

$$\dot{s}(t) = V((-\sigma_T/\alpha)[3\alpha\delta(t)b^2\kappa/qa^3 + (\kappa\sigma_T/q)(s^3(t)/a^3 - 1) - \Sigma_o]) \quad (45)$$

for $t_0 \leq t \leq t_1$. Given the displacement history $\delta(t)$ for $t_0 \leq t \leq t_1$ and the initial position of the phase boundary $s(t_0)$, (45) can, in principle, be solved uniquely for $s(t)$. The displacement field during the quasi-static motion is now given (uniquely) by substituting this $s(t)$ and $\delta(t)$ into (24). The corresponding history of the hoop stress at the cavity is likewise given by (32). We now consider three specific examples of kinetic laws.

5.1. History-independent response

Let φ be the function which is inverse to the kinetic function V ; the kinetic law (42) can then be written in the alternate form

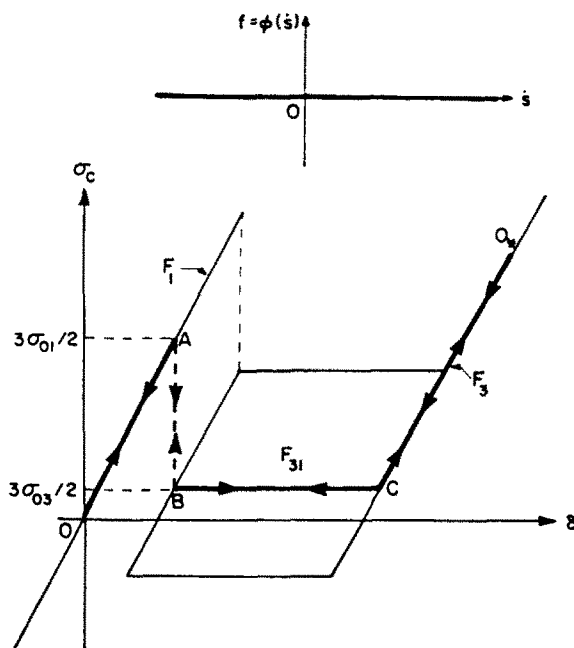

Fig. 5. Dissipation-free response.

$$f(t) = \varphi(\dot{s}(t)) \quad \text{for } t_0 \leq t \leq t_1. \tag{46}$$

Consider the particular kinetic law characterized by

$$\varphi(\dot{s}) = 0 \quad \text{for } -\infty < \dot{s} < \infty \tag{47}$$

which is sketched in Fig. 5; according to this kinetic law the driving traction f on the phase boundary must vanish at all instants during a quasi-static motion.

First consider a motion which, at every instant in $[t_0, t_1]$, is associated with a partially transformed configuration. Equations (46), (47), (38), (39) and (44) then lead to the following relation between $\delta(t)$ and $s(t)$:

$$3\alpha\delta(t)b^2\kappa/qa^3 + (\kappa\sigma_r/q)(s^3(t)/a^3 - 1) = \Sigma_o \quad \text{for } t_0 \leq t \leq t_1. \tag{48}$$

Eliminating s between (48) and (32), and then using (15) gives

$$\sigma_c(t) = 3\sigma_{o3}/2 \quad \text{for } t_0 \leq t \leq t_1. \tag{49}$$

According to (49), during the quasi-static motion, the point $(\delta(t), \sigma_c(t))$ moves along the horizontal line BC in Fig. 5. Recall that while the figure has been drawn for the case $\sigma_{o3} > 0$, this need not be.

Suppose next that the prescribed displacement $\delta(t)$ is increased monotonically (and continuously) from zero, and that at the initial instant the body is in a fully untransformed configuration. The resulting history of the hoop stress is then as shown in Fig. 5: as the point $(\delta(t), \sigma_c(t))$ moves along OA (the sphere remains untransformed and) σ_c increases. When $(\delta(t), \sigma_c(t))$ reaches point A, the particle at the inner wall $r = a$ is at a "Maxwell state" in the sense that the dilatation $\Delta(a) = \Delta_{o1}$ (so that if a phase boundary was initiated at $r = a$ at this instant, the driving traction on it would vanish). If we assume that a phase boundary is in fact initiated at this instant at $r = a$, $(\delta(t), \sigma_c(t))$ now moves from A to B. The hoop stress thus decreases discontinuously from the value $3\sigma_{o1}/2$ to $3\sigma_{o3}/2$. As $\delta(t)$ continues to increase, the motion is now governed by the kinetic law and so, during this stage, $(\delta(t), \sigma_c(t))$ moves along BC, σ_c remains constant, and the phase boundary moves outwards. Eventually, $(\delta(t), \sigma_c(t))$ reaches point C (at which time the phase boundary has

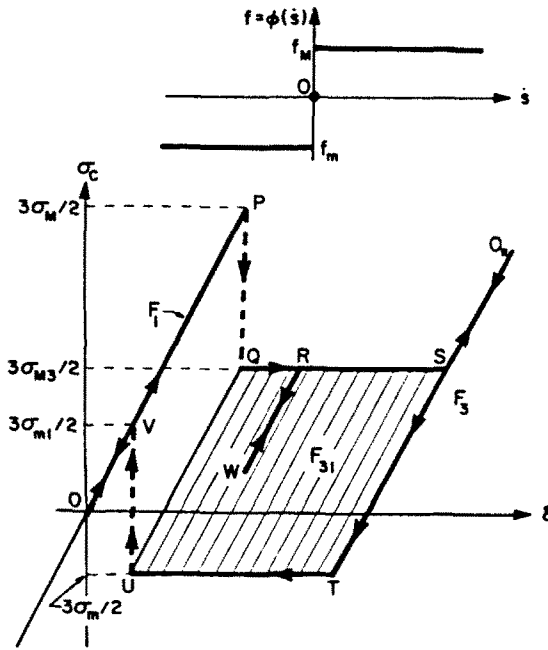

Fig. 6. Maximally dissipative response.

arrived at the outer wall $r = b$) and then commences to move along CO_* . The hoop stress then begins to *increase* once more.

If $\delta(t)$ is decreased monotonically from its value at O_* , $(\delta(t), \sigma_c(t))$ follows the path O_*CBAO . The response is thus reversible, history-independent and dissipation-free.

5.2. History-dependent, rate-independent response

As a second example consider the following choice for the inverse kinetic function φ in (46),

$$\varphi(\dot{s}) = \begin{cases} f_M & \text{for } \dot{s} > 0 \\ f_m & \text{for } \dot{s} < 0 \end{cases} \tag{50}$$

which is sketched in Fig. 6; here f_M and f_m are the maximum and minimum possible values of the driving traction as given by (40), (41). According to this kinetic relation, in order for the phase boundary to move outwards the driving traction f must take on its largest possible value f_M , while if it is to move inwards f must have its smallest possible value f_m ; if f takes on any value between f_m and f_M , the phase boundary must remain stationary (even though the other field quantities might be varying). Thus (46), (50), together with (38), (40), (41), (44) and (15) yield

$$\dot{s} \begin{cases} > 0 & \text{if } \sigma_c = 3\sigma_{M3}/2 \text{ and } \dot{\delta} > 0 \\ < 0 & \text{if } \sigma_c = 3\sigma_m/2 \text{ and } \dot{\delta} < 0 \\ = 0 & \text{otherwise.} \end{cases} \tag{51}$$

As the following two examples show, the response of the body to various prescribed displacement histories $\delta(t)$ may now be determined using (51).

Consider first a monotonically increasing displacement history $\delta(t)$ with $\delta(t_0) = 0$. Suppose further that the initial configuration is a fully untransformed one. The associated variation of the hoop stress is then as shown in Fig. 6: as $(\delta(t), \sigma_c(t))$ moves along OVP , σ_c *increases*. When $(\delta(t), \sigma_c(t))$ reaches point P , the dilatation at the particle at the inner wall $r = a$ is Δ_M (and thus, if a phase boundary is initiated at $r = a$ at this instant, the

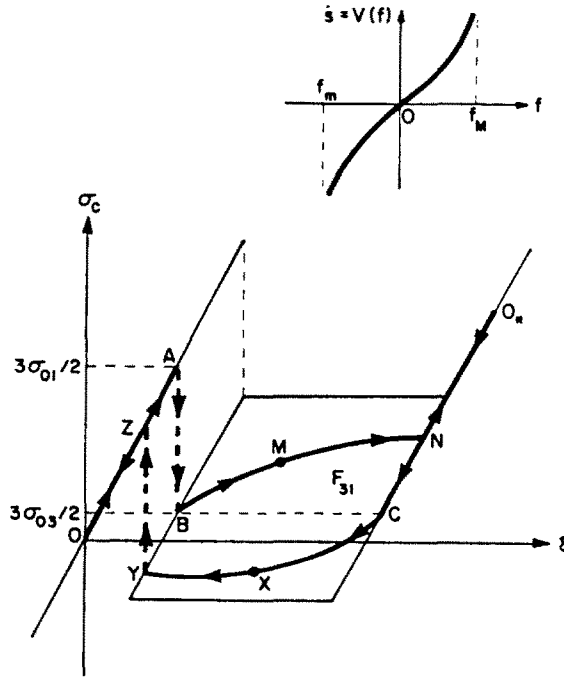

Fig. 7. Response according to kinetic relation shown in inset.

driving traction on it would be f_M). If we assume that a phase boundary is in fact initiated at $r = a$ at this instant, $(\delta(t), \sigma_c(t))$ goes from P to Q and the cavity hoop stress *decreases* discontinuously from the value $3\sigma_M/2$ to $3\sigma_{M3}/2$. The kinetic law (51) governs the next stage of the motion and, accordingly, $(\delta(t), \sigma_c(t))$ proceeds along QRS, the hoop stress remains constant, and the phase boundary propagates outwards. Eventually $(\delta(t), \sigma_c(t))$ reaches the point S (at which time the entire sphere is completely transformed) and then commences to move up SO_* ; σ_c thus begins to *increase* again. If $\delta(t)$ is decreased from its value at O_* the path followed on the (δ, σ_c) -plane is, according to (51), O_*STUVO .

Suppose next that in the preceding example the displacement $\delta(t)$ was only increased until $(\delta(t), \sigma_c(t))$ reached point R, and that thereafter it is monotonically decreased for a short interval of time. According to (51), $s(t)$ must remain constant during this period and therefore $(\delta(t), \sigma_c(t))$ moves down along the line RW. (RW is parallel to QU; recall the discussion following (35)). If $\delta(t)$ is increased again from its value at W, $(\delta(t), \sigma_c(t))$ follows the path WRSO*, so that the phase boundary continues to remain stationary for a while (WR) but then resumes its outward motion.

The response of the sphere according to the kinetic relation (50) is thus seen to be "plasticity-like". Note that quasi-static motions of the sphere are dissipative at all instants during which the phase boundary is in motion (since then $f\dot{s} > 0$) but non-dissipative when the phase boundary is stationary. This particular kinetic law is equivalent to the "flow-rule" used by Budiansky *et al.* (1983).

5.3. History-dependent, rate-dependent response

As a final example, consider the kinetic function $V(f)$ shown in Fig. 7: V increases monotonically on (f_m, f_M) , $V(0) = 0$, $V(f) \rightarrow \infty$ as $f \rightarrow f_M$, and $V(f) \rightarrow -\infty$ as $f \rightarrow f_m$. Suppose that $\delta(t) = \lambda t$ where $\lambda > 0$ is the (constant) loading rate. During the resulting motion, the point $(\delta(t), \sigma_c(t))$ moves along the curve OABMNO* shown *schematically* in Fig. 7. The sphere initially remains untransformed (OZA). When $\Delta(a) = \Delta_{o1}$ (point A) we assume that a phase boundary is initiated at $r = a$; the driving traction on this phase boundary at the instant of initiation is zero. As in all cases, the kinetic law is now operative and governs the evolution of the phase boundary. The equation of the curve BMN is found by solving the differential equation (45) with $\delta(t) = \lambda t$ subject to the initial condition $s = a$. It is clear that, in general, different loading rates λ will give rise to different curves BMN.

When the rate at which $V(f) \rightarrow \pm \infty$ is sufficiently large, one can show that the curve BMN does not intersect the upper horizontal boundary of the parallelogram F_{31} . (If V does not increase fast enough, the path will intersect the upper boundary; this means that the sphere cannot be deformed beyond this point of intersection, at that same rate of loading.) Eventually, the phase boundary reaches the outer wall (point N). Note that during this motion, the cavity hoop stress σ_c first increases, then decreases discontinuously as the phase transformation is initiated, then increases slowly† (as the phase boundary propagates), and finally (once the entire body has been transformed) increases at the same rate as during the initial stage. Unloading follows the path O_*CXYZO .

As a second example of a loading history, suppose that the initial configuration of the body is that associated with any point, say M , in F_{31} . Suppose further, that the displacement $\delta(t)$ is held constant thereafter. Since the driving traction f on the phase boundary does not vanish in general, the phase boundary will move according to the kinetic law. The motion of the body may be determined by first finding $s(t)$ by solving the differential equation (45) with $\delta(t) = \text{constant}$, and then substituting the result into (24). The path followed in the (δ, σ_c) -plane is the vertical line through M . The phase boundary eventually comes to rest when the driving traction becomes zero which happens when $(\delta(t), \sigma_c(t))$ reaches the line BC.

Acknowledgements—The authors are grateful to John W. Hutchinson for having read and commented on this manuscript, and to Stewart A. Silling for helpful comments during the course of this work. A parallel study in the finite theory was carried out by one of us (R.A.) in collaboration with James K. Knowles.

REFERENCES

- Abeyaratne, R. and Jiang, G.-H. (1989). Dilatationally nonlinear elastic materials—I. Some theory. *Int. J. Solids Structures* **25**, 1201–1219.
- Abeyaratne, R. and Knowles, J. K. (1987). Non-elliptic elastic materials and the modeling of dissipative mechanical behavior: an example. *J. Elasticity* **18**, 227–278.
- Amazigo, J. C. and Budiansky, B. (1987). Interaction of particulate and transformation toughening. Harvard University technical report MECH-112.
- Amazigo, J. C. and Budiansky, B. (1988). Steady state crack growth in supercritically transforming materials. *Int. J. Solids Structures* **24**, 751–755.
- Budiansky, B., Hutchinson, J. W. and Lambropoulos, J. C. (1983). Continuum theory of dilatant transformation toughening in ceramics. *Int. J. Solids Structures* **19**, 337–355.
- Evans, A. G. and Cannon, R. (1986). Toughening of brittle solids by martensitic transformations. *Acta Metall.* **34**, 761–800.
- Garvie, R. C., Hannink, R. H. and Pascoe, R. T. (1975). Ceramic steel? *Nature* **258**, 703–704.
- Knowles, J. K. (1979). On the dissipation associated with equilibrium shocks in finite elasticity. *J. Elasticity* **9**, 131–158.
- Lambropoulos, J. (1986). Shear, shape and orientation effects in transformation toughening. *Int. J. Solids Structures* **22**, 1083–1106.
- McMeeking, R. M. and Evans, A. G. (1982). Mechanics of transformation toughening in brittle materials. *J. Am. Ceramic Soc.* **65**, 242–246.
- Ortiz, M. (1987). A continuum theory of crack shielding in ceramics. *J. Appl. Mech.* **54**, 54–58.
- Silling, S. A. (1987). The effect of supercritical dilatational transformation on crack-tip singularities. Brown University technical report.

† In view of the admissibility condition (43), one can show that no matter what the kinetic law, the slope of the curve BMN can nowhere exceed the slope of the straight lines OA and NO_* .